

DURBAL® Premium Line
Hochleistungs-Gelenkköpfe mit integrierter Pendelkugellagerung, Innengewinde, Abmessungen in Zoll

heavy-duty rod ends with integral self-aligning ball bearing, female thread, dimensions in inches

➤ Sonderanfertigungen auf Anfrage
 ➤ Custom made products on request

Gehäuse:
 geschmiedeter Einsatzstahl, vergütet, Laufbahn gehärtet und feinstbearbeitet, Oberfläche galvanisch verzinkt, Cr VI-frei

Innenring:
 Wälzlagerstahl, gehärtet, feinstbearbeitet

Wälzkörper:
 Wälzlagerstahl, gehärtet, feinstbearbeitet

Wartung:
 wartungsarm, nachschmierbar, be fettet mit Aluminiumkomplexeisenfett, Zulassung nach USDA H1, Temperaturbereich -45° C bis +120° C

Schmiernippel:
 Trichterschmiernippel DIN 3405 D1/A (bis Größe 10) / Kegelschmiernippel DIN 71 412 H1 (ab Größe 12), weitere Schmiernippel siehe Seite 050

Toleranzen:
 Seite 042 - 049

housing:
 forged steel, case hardened bearing race, superfinished, surface galvanized, free of Cr VI

inner ring:
 ball bearing steel, hardened, superfinished

rolling element:
 roller bearing steel, hardened, superfinished

maintenance:
 low maintenance, lubrication possible, aluminium-complex-soap-grease, approval according to USDA H1, temperature range -45° C bis +120° C

grease nipple:
 DIN 3405 D1/A (until size 10) / DIN 71 412 H1 (from size 12), further grease nipples see on page 050

tolerances:
 page 042 - 049

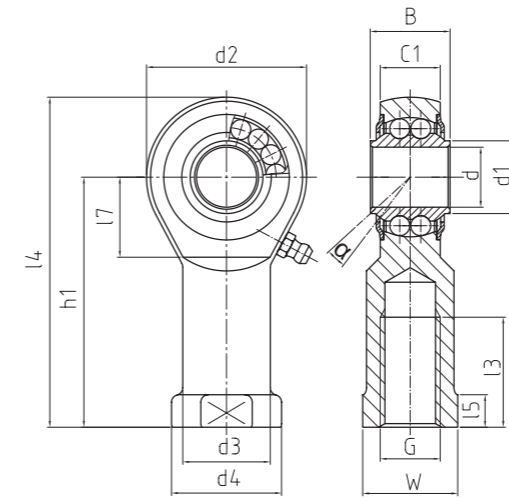

BRF^{ZOLL}

BRF - ZOLL
 Hochleistungs-Gelenkkopf
 Heavy-duty rod end

➤ Premium Line



Bestellnummer order number			Abmessungen (Zoll) / [1 Zoll/inch = 25,4 mm] measurements (inches)											Kippwinkel tilt angle	Gewicht weight	Drehzahlgrenze rotational speed limit	Axialfaktoren axial factor		Tragzahlen basic load rating		Radiale Lagerluft radial clearance			
Typ type	Rechtsgewinde right hand thread	Linksgewinde left hand thread	d	G	B	C1	h1	d1	d2	d3	d4	l3	l4	l5	l7	W	α (°)	(kg)	"max. (min-1)	Y	Y0	dyn C (kN)	stat Co (kN)	CN (µm)
BRF 1/4 - 00	-501	-502	.250	1/4 - 28 UNF	.354	.265	1.200	.356	.787	.393	.511	.472	1.593	.240	.452	.433	8	0,027	1.350	2,09	2,19	2,7	0,7	10 - 30
BRF 3/8 - 00	-501	-502	.375	3/8 - 24 UNF	.551	.413	1.712	.468	1.102	.590	.748	.787	2.263	.299	.590	.669	8	0,072	1.225	1,87	1,83	4,4	1,4	10 - 30
BRF 1/2 - 00	-501	-502	.500	1/2 - 20 UNF	.624	.472	2.145	.574	1.311	.748	.874	1.102	2.801	.279	.649	.757	7,5	0,127	1.125	1,74	1,82	4,9	1,9	10 - 30
BRF 5/8 - 00	-501	-502	.625	5/8 - 18 UNF	.826	.590	2.539	.744	1.653	.866	1.062	1.102	3.366	.322	.885	.866	8	0,22	975	2,24	2,35	6,3	2,4	10 - 30
BRF 3/4 - 00	-501	-502	.750	3/4 - 16 UNF	.984	.688	3.051	.956	1.750	1.000	1.125	1.299	3.926	.409	1.043	1.007	7	0,39	825	2,32	2,43	7,8	3,4	10 - 30
BRF 1/1 - 00	-501	-502	1.000	1/1 - 12 UNF	1.220	.866	3.720	1.161	2.519	1.171	1.377	1.653	4.980	.236	1.279	1.181	5	0,57	600	2,02	2,12	11	5,7	10 - 30
BRF 1/1 - 01	-501	-502	1.000	1/1 - 14 UNS	1.220	.866	3.720	1.161	2.519	1.171	1.377	1.653	4.980	.236	1.279	1.181	5	0,57	600	2,02	2,12	11	5,7	10 - 30