

**DURBAL® Classic Line**

**Hochleistungs-Gelenkköpfe mit fixiertem Gleitlager, Maßreihe E / EH, Innengewinde, Anschlussmaße nach DIN ISO 12240-4 und DIN ISO 8139**

**heavy-duty rod ends with pressed spherical-plain bearing, series E / EH, female thread, according to DIN ISO 12240-4 and thread according to DIN ISO 8139**

➤ Sonderanfertigungen auf Anfrage  
➤ Custom made products on request

**Gehäuse:**

Vergütungsstahl, vergütet, Oberfläche galvanisch verzinkt, Cr VI-frei

**Außenring:**

Wälzlagerstahl, gehärtet, geschliffen, phosphatiert, an Sollbruchstelle gesprengt, mit Schmiernut und -bohrung, mit beidseitiger -2RS -Abdichtung

**Gelenkkugel:**

Wälzlagerstahl, gehärtet, geschliffen, phosphatiert

**Wartung:**

wartungspflichtig, nachschmierbar

**Schmiernippel:**

Trichterschmiernippel DIN 3405 D1/A (ab Größe 15 bis 17) / Kegelschmiernippel DIN 71 412 H1 (ab Größe 20 bis 60), weitere Schmiernippel siehe Seite 050

**Toleranzen:**

Seite 042 - 049

**housing:**

heat-treated steel, tempered, surface galvanized, free of Cr VI

**outer ring:**

ball bearing steel, hardened, ground, phosphated, single split, oil groove and drill holes, with -2RS lip seals on both sides

**joint ball:**

ball bearing steel, hardened, ground, phosphated

**maintenance:**

maintenance required, lubrication possible

**grease nipple:**

DIN 3405 D1/A (sizes 15 to 17) / DIN 71 412 H1 (sizes 20 to 60), further grease nipples see on page 050

**tolerances:**

page 042 - 049

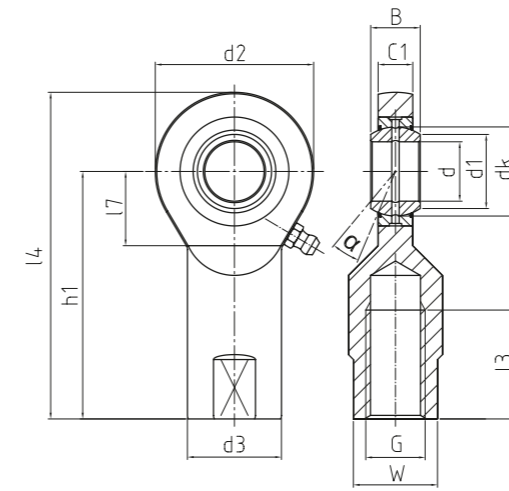

EFN -2RS

Hochleistungs-Gelenkkopf  
Heavy-duty rod end

➤ Classic Line



Bestellnummer order number			Abmessungen measurements (mm)										Kippwinkel tilt angle	Gewicht weight	Tragzahl basic load rating	Radiale Lagerluft radial clearance				
Typ type	Rechtsgewinde right hand thread	Linksgewinde left hand thread	d	G	B	C1	h1	d1	d2	d3	dk	l3	l4	l7	W	α (°)	(kg)	stat Co (kN)	CN (µm)	d
EFN 15 - 30	-501	-502	15	M 14	12	9	61	18	38	22	22	25	80	18	19	8	0,18	36	20 - 60	15
EFN 17 - 30	-501	-502	17	M 16	14	10	67	20	44	25	25	28	89	20	22	10	0,22	45	20 - 60	17
EFN 17 - 31	-501	-502	17	M 16 x 1,5	14	10	67	20	44	25	25	28	89	20	22	10	0,22	45	20 - 60	17
EFN 20 - 30	-501	-502	20	M 20 x 1,5	16	12	77	24	51	28	29	33	102,5	23	24	9	0,35	60	20 - 60	20
EFN 25 - 30	-501	-502	25	M 24 x 2	20	16	94	29	62	35	35,5	42	125	30	30	7	0,64	83	30 - 100	25
EFN 30 - 30	-501	-502	30	M 30 x 2	22	18	110	34	70	42	40,7	51	145	32	36	6	0,93	110	30 - 100	30
EFN 35 - 30	-501	-502	35	M 36 x 3	25	20	125	39	82	51	47	61	166	38	41	6	1,3	146	30 - 100	35
EFN 35 - 31	-501	-502	35	M 36 x 2	25	20	130	39	82	51	47	66	171	38	41	6	1,3	146	30 - 100	35
EFN 40 - 30	-501	-502	40	M 42 x 3	28	22	145	45	92	60	53	71	191	42	50	7	2	180	40 - 120	40
EFN 40 - 31	-501	-502	40	M 39 x 3	28	22	142	45	92	52	53	66	188	42	46	7	1,8	180	40 - 120	40
EFN 45 - 30	-501	-502	45	M 45 x 3	32	25	165	50	102	67	60	76	216	50	55	7	2,5	240	40 - 120	45
EFN 45 - 31	-501	-502	45	M 42 x 3	32	25	145	50	102	58	60	66	196	50	50	7	1,9	240	40 - 120	45
EFN 50 - 30	-501	-502	50	M 52 x 3	35	28	195	55	112	72	66	89	251	60	60	6	3,5	290	40 - 120	50
EFN 50 - 31	-501	-502	50	M 45 x 3	35	28	160	55	112	62	66	69	216	60	55	6	3	290	40 - 120	50
EFN 60 - 30	-501	-502	60	M 60 x 4	44	36	225	66	135	84	80	103	292,5	70	70	6	5,5	450	40 - 120	60
EFN 60 - 31	-501	-502	60	M 52 x 3	44	36	175	66	135	71	80	71	242,5	70	60	6	4	450	40 - 120	60