

OVER EXTENSIONS



PAGE 76

5.1 PRODUCT OVERVIEW

PAGE 78

5.2 OVER EXTENSIONS

- NTSU40-52DS
- NTU48-35DC
- NTSU50-60DS
- NTU59-41.5DC
- NTSU60-40
- NTSU60-68DS
- NTU72-30T
- NTU72-47.5DC
- NTSU80-43
- NTSU80-79DS
- NTSU100-51
- NTSU100-98DS
- NTSU150-64

PRODUCT OVERVIEW

OVER EXTENSIONS

NTSU40-52DS

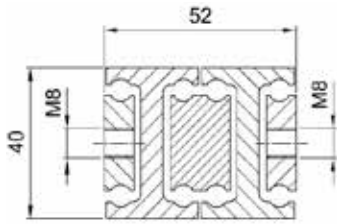

NTU48-35DC

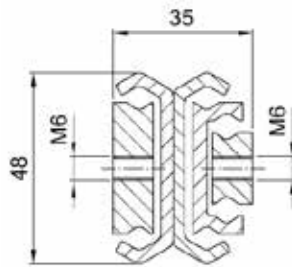

NTSU50-60DS

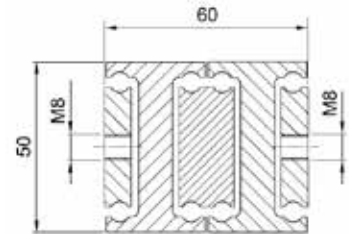

NTU59-41.5DC

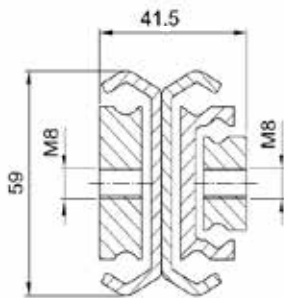

NTSU60-40

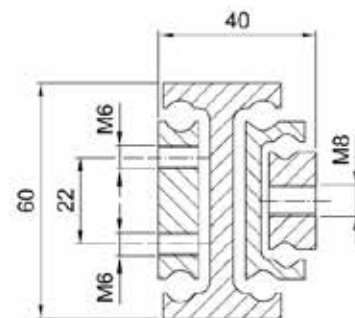

NTSU60-68DS

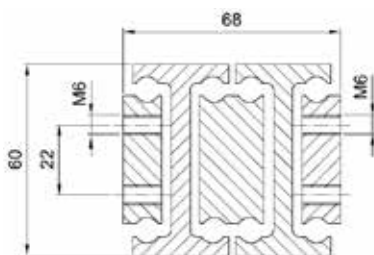

NTU72-30T

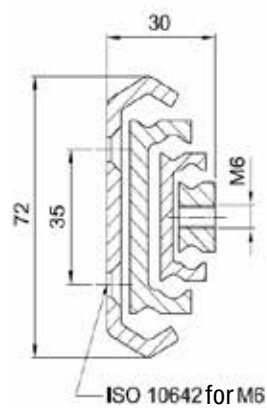

NTU72-47.5DC

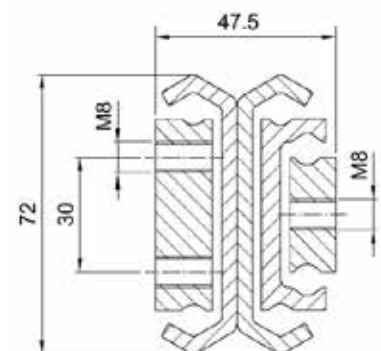

NTSU80-43

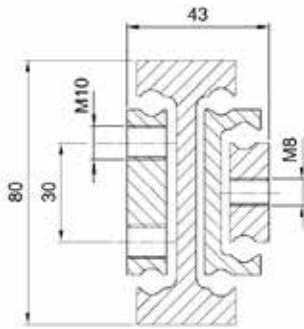

NTSU80-79DS

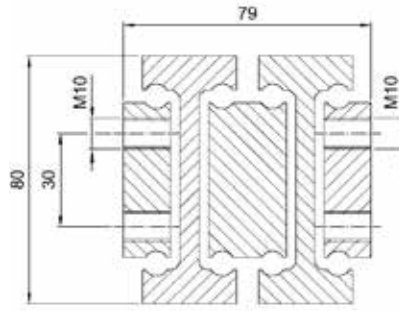

NTSU100-51

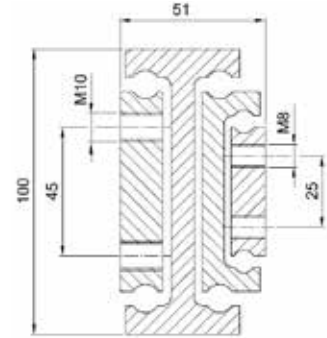

NTSU100-98DS

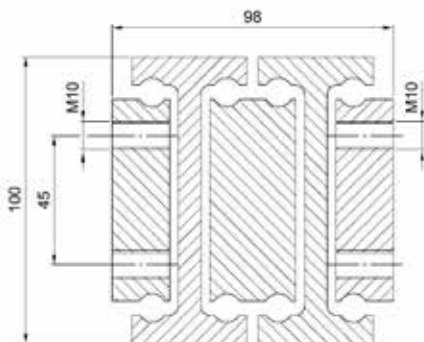

NTSU150-64

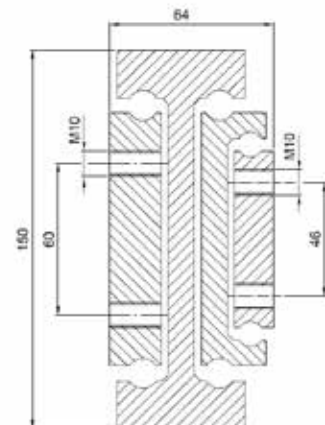

OVER EXTENSION

NTSU40-52DS

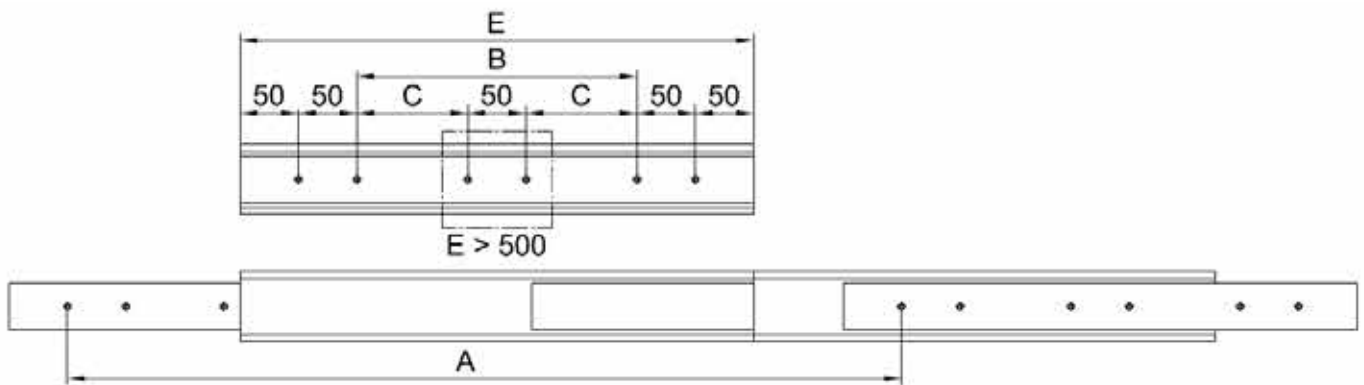
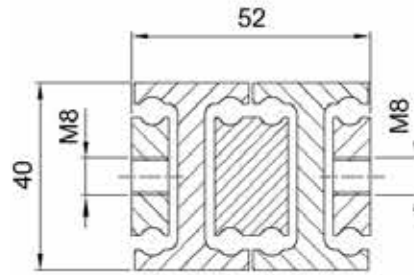

Load Table

| Order Number | Hole separation (mm) | | Installation length (mm) | Extension length (mm) | Net weight (kg) | Maximum load/pair (N) |
|------------------|----------------------|-----|--------------------------|-----------------------|-----------------|-----------------------|
| | B | C | E | A | | |
| NTSU40-52DS-250 | 50 | | 250 | 375 | 2.0 | 600 |
| NTSU40-52DS-300 | 100 | | 300 | 450 | 2.5 | 650 |
| NTSU40-52DS-350 | 150 | | 350 | 525 | 2.9 | 710 |
| NTSU40-52DS-400 | 200 | | 400 | 600 | 3.3 | 750 |
| NTSU40-52DS-450 | 250 | | 450 | 675 | 3.7 | 750 |
| NTSU40-52DS-500 | 300 | | 500 | 750 | 4.1 | 750 |
| NTSU40-52DS-550 | | 150 | 550 | 825 | 4.5 | 750 |
| NTSU40-52DS-600 | | 175 | 600 | 900 | 4.9 | 710 |
| NTSU40-52DS-650 | | 200 | 650 | 975 | 5.3 | 710 |
| NTSU40-52DS-700 | | 225 | 700 | 1050 | 5.7 | 650 |
| NTSU40-52DS-750 | | 250 | 750 | 1125 | 6.1 | 600 |
| NTSU40-52DS-800 | | 275 | 800 | 1200 | 6.5 | 550 |
| NTSU40-52DS-850 | | 300 | 850 | 1275 | 7.0 | 500 |
| NTSU40-52DS-900 | | 325 | 900 | 1350 | 7.4 | 450 |
| NTSU40-52DS-950 | | 350 | 950 | 1425 | 7.8 | 380 |
| NTSU40-52DS-1000 | | 375 | 1000 | 1500 | 8.2 | 350 |
| NTSU40-52DS-1100 | | 425 | 1100 | 1675 | 9.0 | 320 |
| NTSU40-52DS-1200 | | 475 | 1200 | 1750 | 9.8 | 300 |

Ordercode and further options see last page. Your desired length is not listed in the table? No problem! Only the most common lengths are shown here. Please contact our application technology division.

NTU48-35DC

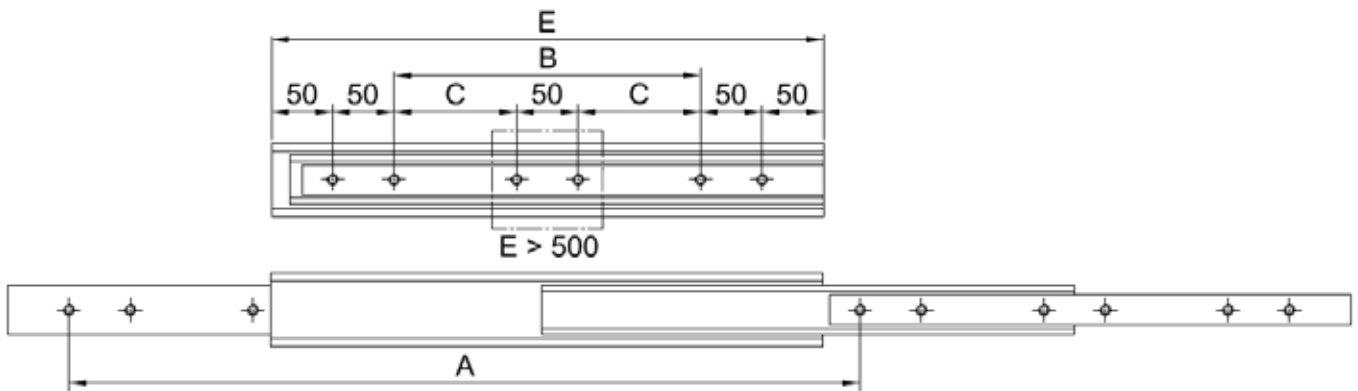
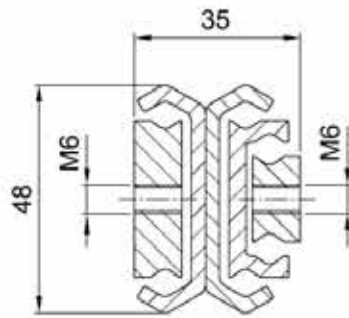

Load Table

| Order Number | Hole separation (mm) | | Installation length (mm) | Extension length (mm) | Net weight (kg) | Maximum load/pair (N) |
|-----------------|----------------------|-----|--------------------------|-----------------------|-----------------|-----------------------|
| | B | C | E | A | | |
| NTU48-35DC-250 | 50 | | 250 | 375 | 2.0 | 600 |
| NTU48-35DC-300 | 100 | | 300 | 450 | 2.5 | 650 |
| NTU48-35DC-350 | 150 | | 350 | 525 | 2.9 | 710 |
| NTU48-35DC-400 | 200 | | 400 | 600 | 3.3 | 750 |
| NTU48-35DC-450 | 250 | | 450 | 675 | 3.7 | 750 |
| NTU48-35DC-500 | 300 | | 500 | 750 | 4.1 | 750 |
| NTU48-35DC-550 | | 150 | 550 | 825 | 4.5 | 750 |
| NTU48-35DC-600 | | 175 | 600 | 900 | 4.9 | 710 |
| NTU48-35DC-650 | | 200 | 650 | 975 | 5.3 | 710 |
| NTU48-35DC-700 | | 225 | 700 | 1050 | 5.7 | 650 |
| NTU48-35DC-750 | | 250 | 750 | 1125 | 6.1 | 600 |
| NTU48-35DC-800 | | 275 | 800 | 1200 | 6.5 | 550 |
| NTU48-35DC-850 | | 300 | 850 | 1275 | 7.0 | 500 |
| NTU48-35DC-900 | | 325 | 900 | 1350 | 7.4 | 450 |
| NTU48-35DC-950 | | 350 | 950 | 1425 | 7.8 | 380 |
| NTU48-35DC-1000 | | 375 | 1000 | 1500 | 8.2 | 350 |
| NTU48-35DC-1100 | | 425 | 1100 | 1675 | 9.0 | 320 |
| NTU48-35DC-1200 | | 475 | 1200 | 1750 | 9.8 | 300 |

Ordercode and further options see last page. Your desired length is not listed in the table? No problem! Only the most common lengths are shown here. Please contact our application technology division.

OVER EXTENSION

NTSU50-60DS

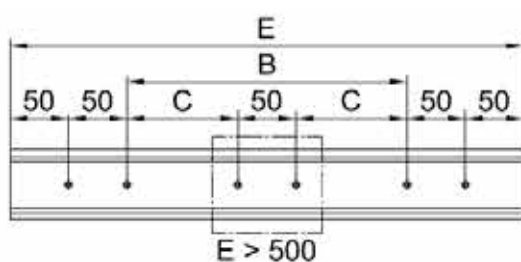
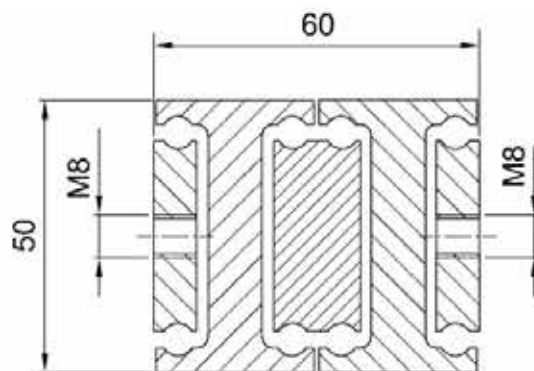

Load Table

| Order Number | Hole separation (mm) | | Installation length (mm) | Extension length (mm) | Net weight (kg) | Maximum load/pair (N) |
|------------------|----------------------|-----|--------------------------|-----------------------|-----------------|-----------------------|
| | B | C | E | A | | |
| NTSU50-60DS-300 | 100 | | 300 | 450 | 3,3 | 1800 |
| NTSU50-60DS-350 | 150 | | 350 | 525 | 3,8 | 1900 |
| NTSU50-60DS-400 | 200 | | 400 | 600 | 4,4 | 1950 |
| NTSU50-60DS-450 | 250 | | 450 | 675 | 4,9 | 2000 |
| NTSU50-60DS-500 | 300 | | 500 | 750 | 5,5 | 2000 |
| NTSU50-60DS-550 | | 150 | 550 | 825 | 6,0 | 1950 |
| NTSU50-60DS-600 | | 175 | 600 | 900 | 6,6 | 1900 |
| NTSU50-60DS-650 | | 200 | 650 | 975 | 7,1 | 1850 |
| NTSU50-60DS-700 | | 225 | 700 | 1050 | 7,7 | 1800 |
| NTSU50-60DS-750 | | 250 | 750 | 1125 | 8,2 | 1750 |
| NTSU50-60DS-800 | | 275 | 800 | 1200 | 8,8 | 1700 |
| NTSU50-60DS-850 | | 300 | 850 | 1275 | 9,3 | 1630 |
| NTSU50-60DS-900 | | 325 | 900 | 1350 | 9,9 | 1560 |
| NTSU50-60DS-950 | | 350 | 950 | 1425 | 10,4 | 1490 |
| NTSU50-60DS-1000 | | 375 | 1000 | 1500 | 11,0 | 1420 |
| NTSU50-60DS-1100 | | 425 | 1100 | 1650 | 12,1 | 1290 |
| NTSU50-60DS-1200 | | 475 | 1200 | 1800 | 13,2 | 1160 |
| NTSU50-60DS-1300 | | 525 | 1300 | 1950 | 14,3 | 1020 |
| NTSU50-60DS-1400 | | 575 | 1400 | 2100 | 15,4 | 860 |
| NTSU50-60DS-1500 | | 625 | 1500 | 2250 | 16,5 | 700 |

Ordercode and further options see last page. Your desired length is not listed in the table? No problem! Only the most common lengths are shown here. Please contact our application technology division.

NTU59-41.5DC

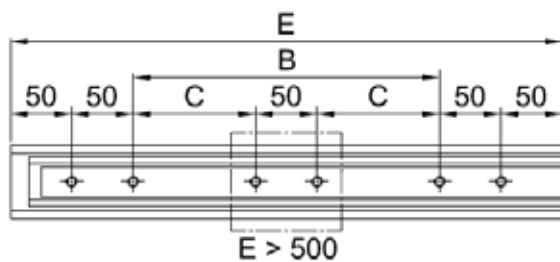
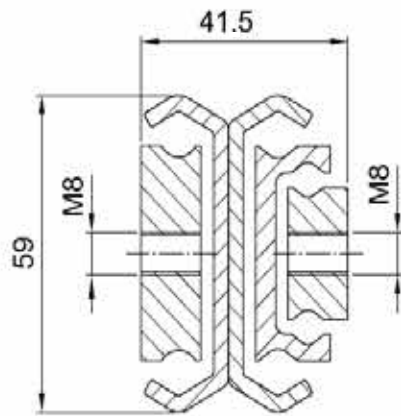

Load Table

| Order Number | Hole separation (mm) | | Installation length (mm) | Extension length (mm) | Net weight (kg) | Maximum load/pair (N) |
|-------------------|----------------------|-----|--------------------------|-----------------------|-----------------|-----------------------|
| | B | C | E | A | | |
| NTU59-41.5DC-300 | 100 | | 300 | 450 | 3.3 | 1800 |
| NTU59-41.5DC-350 | 150 | | 350 | 525 | 3.8 | 1900 |
| NTU59-41.5DC-400 | 200 | | 400 | 600 | 4.4 | 1950 |
| NTU59-41.5DC-450 | 250 | | 450 | 675 | 4.9 | 2000 |
| NTU59-41.5DC-500 | 300 | | 500 | 750 | 5.5 | 2000 |
| NTU59-41.5DC-550 | | 150 | 550 | 825 | 6.0 | 1950 |
| NTU59-41.5DC-600 | | 175 | 600 | 900 | 6.6 | 1900 |
| NTU59-41.5DC-650 | | 200 | 650 | 975 | 7.1 | 1850 |
| NTU59-41.5DC-700 | | 225 | 700 | 1050 | 7.7 | 1800 |
| NTU59-41.5DC-750 | | 250 | 750 | 1125 | 8.2 | 1750 |
| NTU59-41.5DC-800 | | 275 | 800 | 1200 | 8.8 | 1700 |
| NTU59-41.5DC-850 | | 300 | 850 | 1275 | 9.3 | 1630 |
| NTU59-41.5DC-900 | | 325 | 900 | 1350 | 9.9 | 1560 |
| NTU59-41.5DC-950 | | 350 | 950 | 1425 | 10.4 | 1490 |
| NTU59-41.5DC-1000 | | 375 | 1000 | 1500 | 11.0 | 1420 |
| NTU59-41.5DC-1100 | | 425 | 1100 | 1650 | 12.1 | 1290 |
| NTU59-41.5DC-1200 | | 475 | 1200 | 1800 | 13.2 | 1160 |
| NTU59-41.5DC-1300 | | 525 | 1300 | 1950 | 14.3 | 1020 |
| NTU59-41.5DC-1400 | | 625 | 1400 | 2100 | 15.4 | 860 |

Ordercode and further options see last page. Your desired length is not listed in the table? No problem! Only the most common lengths are shown here. Please contact our application technology division.

OVER EXTENSION

NTSU60-40

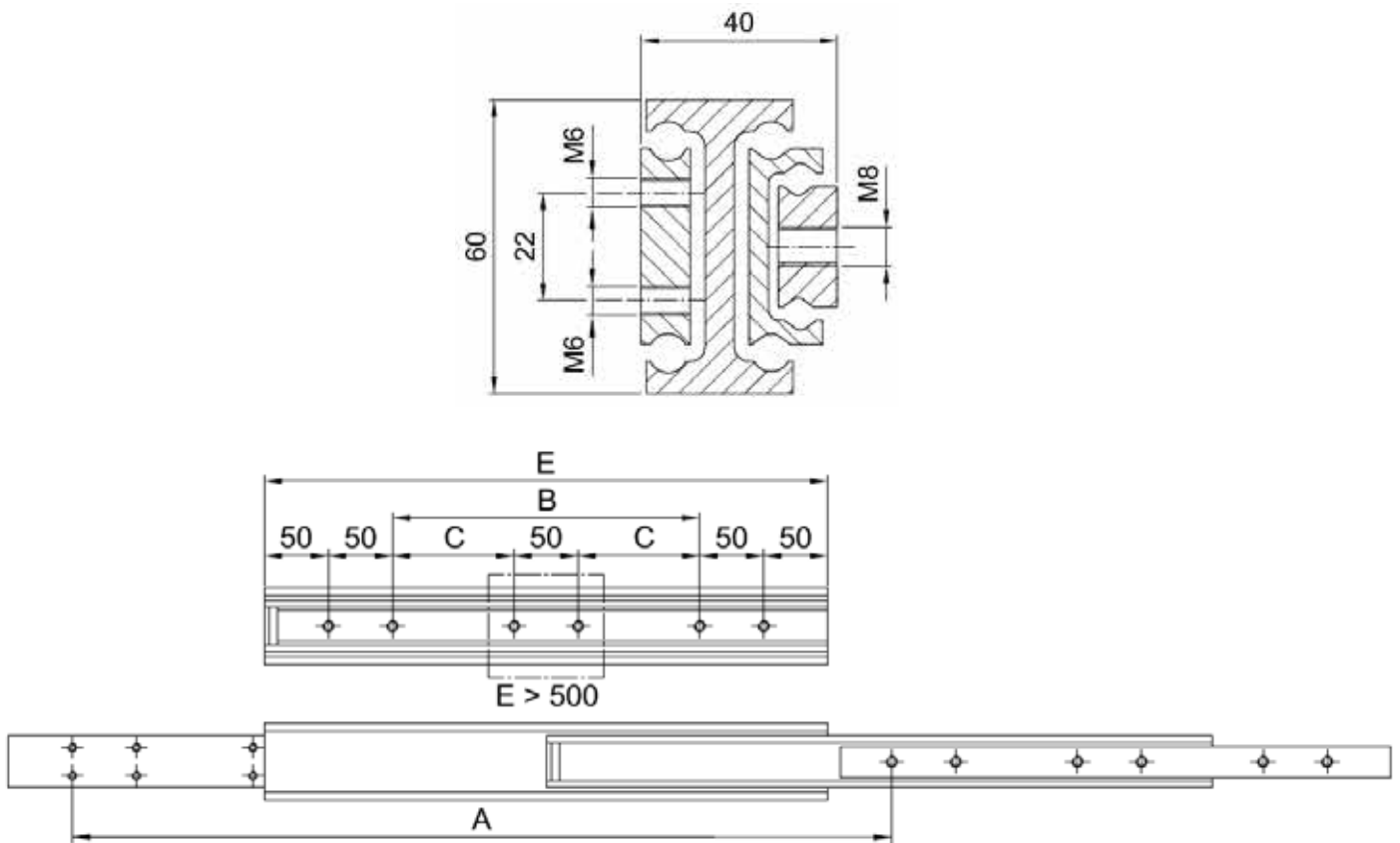

| Order Number | Load Table | | | | | |
|----------------|----------------------|-----|--------------------------|-----------------------|-----------------|-----------------------|
| | Hole separation (mm) | | Installation length (mm) | Extension length (mm) | Net weight (kg) | Maximum load/pair (N) |
| | B | C | E | A | | |
| NTSU60-40-300 | 100 | | 300 | 450 | 4.1 | 2500 |
| NTSU60-40-350 | 150 | | 350 | 525 | 4.7 | 2600 |
| NTSU60-40-400 | 200 | | 400 | 600 | 5.3 | 2650 |
| NTSU60-40-450 | 250 | | 450 | 675 | 6.0 | 2700 |
| NTSU60-40-500 | 300 | | 500 | 750 | 6.6 | 2700 |
| NTSU60-40-550 | | 150 | 550 | 825 | 7.3 | 1650 |
| NTSU60-40-600 | | 175 | 600 | 900 | 7.9 | 2600 |
| NTSU60-40-650 | | 200 | 650 | 975 | 8.6 | 2550 |
| NTSU60-40-700 | | 225 | 700 | 1050 | 9.2 | 2500 |
| NTSU60-40-750 | | 250 | 750 | 1125 | 9.9 | 2450 |
| NTSU60-40-800 | | 275 | 800 | 1200 | 10.5 | 2400 |
| NTSU60-40-850 | | 300 | 850 | 1275 | 11.1 | 2350 |
| NTSU60-40-900 | | 325 | 900 | 1350 | 11.8 | 2300 |
| NTSU60-40-950 | | 350 | 950 | 1425 | 12.4 | 2250 |
| NTSU60-40-1000 | | 375 | 1000 | 1500 | 13.1 | 2200 |
| NTSU60-40-1100 | | 425 | 1100 | 1650 | 14.3 | 2100 |
| NTSU60-40-1200 | | 475 | 1200 | 1800 | 15.6 | 1950 |
| NTSU60-40-1300 | | 525 | 1300 | 1950 | 16.9 | 1800 |
| NTSU60-40-1400 | | 575 | 1400 | 2100 | 18.2 | 1650 |
| NTSU60-40-1500 | | 625 | 1500 | 2250 | 19.5 | 1500 |

Ordercode and further options see last page. Your desired length is not listed in the table? No problem! Only the most common lengths are shown here. Please contact our application technology division.

NTSU60-68DS

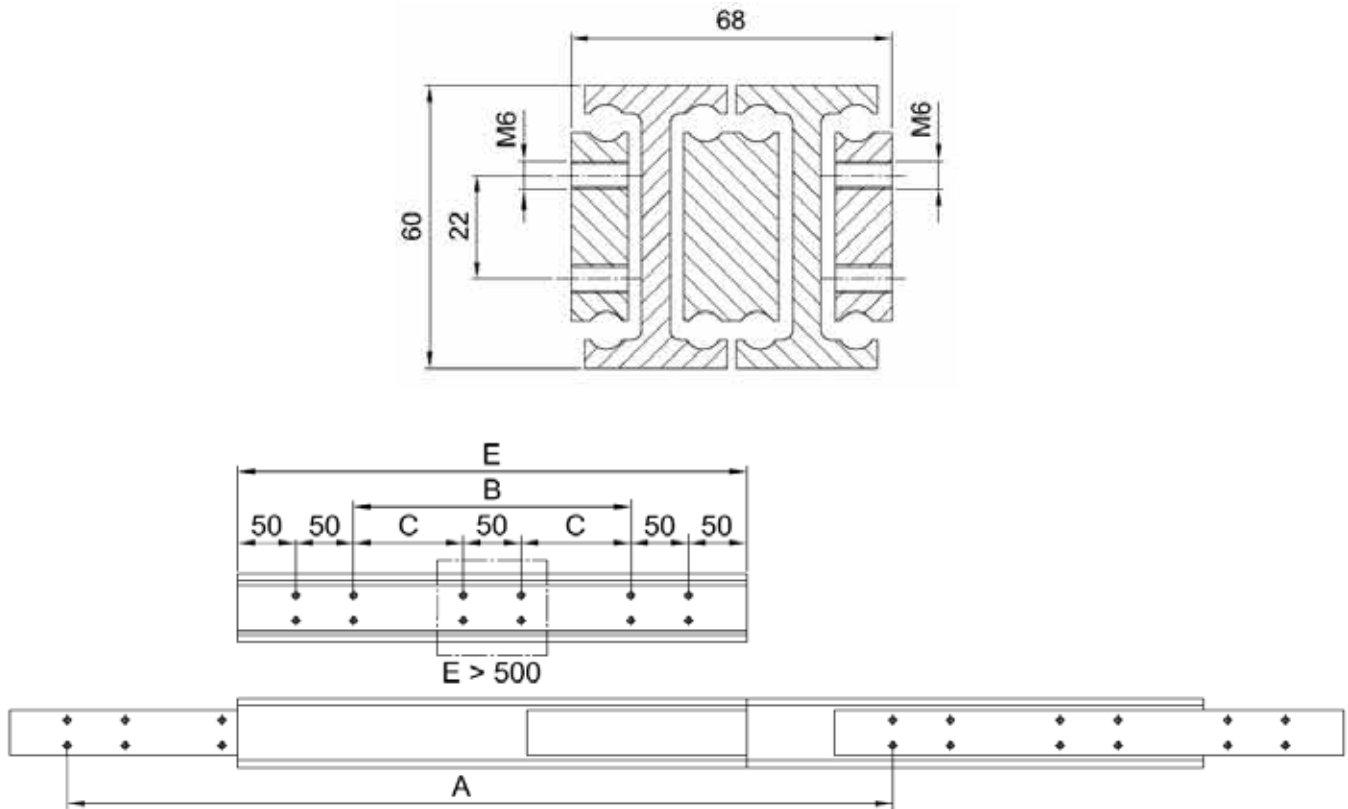

| Order Number | Load Table | | | | | |
|------------------|----------------------|-----|--------------------------|-----------------------|-----------------|-----------------------|
| | Hole separation (mm) | | Installation length (mm) | Extension length (mm) | Net weight (kg) | Maximum load/pair (N) |
| | B | C | E | A | | |
| NTSU60-68DS-500 | 300 | | 500 | 1000 | 11.5 | 7120 |
| NTSU60-68DS-550 | | 150 | 550 | 1100 | 12.6 | 7250 |
| NTSU60-68DS-600 | | 175 | 600 | 1200 | 13.8 | 7120 |
| NTSU60-68DS-650 | | 200 | 650 | 1300 | 14.9 | 7050 |
| NTSU60-68DS-700 | | 225 | 700 | 1400 | 16.0 | 7050 |
| NTSU60-68DS-750 | | 250 | 750 | 1500 | 17.1 | 6730 |
| NTSU60-68DS-800 | | 275 | 800 | 1600 | 18.2 | 6470 |
| NTSU60-68DS-850 | | 300 | 850 | 1700 | 19.4 | 6210 |
| NTSU60-68DS-900 | | 325 | 900 | 1800 | 20.5 | 5950 |
| NTSU60-68DS-950 | | 350 | 950 | 1900 | 21.7 | 5690 |
| NTSU60-68DS-1000 | | 375 | 1000 | 2000 | 22.8 | 5360 |
| NTSU60-68DS-1100 | | 425 | 1100 | 2200 | 25.0 | 4910 |
| NTSU60-68DS-1200 | | 475 | 1200 | 2400 | 27.3 | 4390 |
| NTSU60-68DS-1300 | | 525 | 1300 | 2600 | 29.6 | 3870 |
| NTSU60-68DS-1400 | | 576 | 1400 | 2800 | 31.8 | 3550 |
| NTSU60-68DS-1500 | | 625 | 1500 | 3000 | 34.1 | 2830 |

Ordercode and further options see last page. Your desired length is not listed in the table? No problem! Only the most common lengths are shown here. Please contact our application technology division.

OVER EXTENSION

NTU72-30T

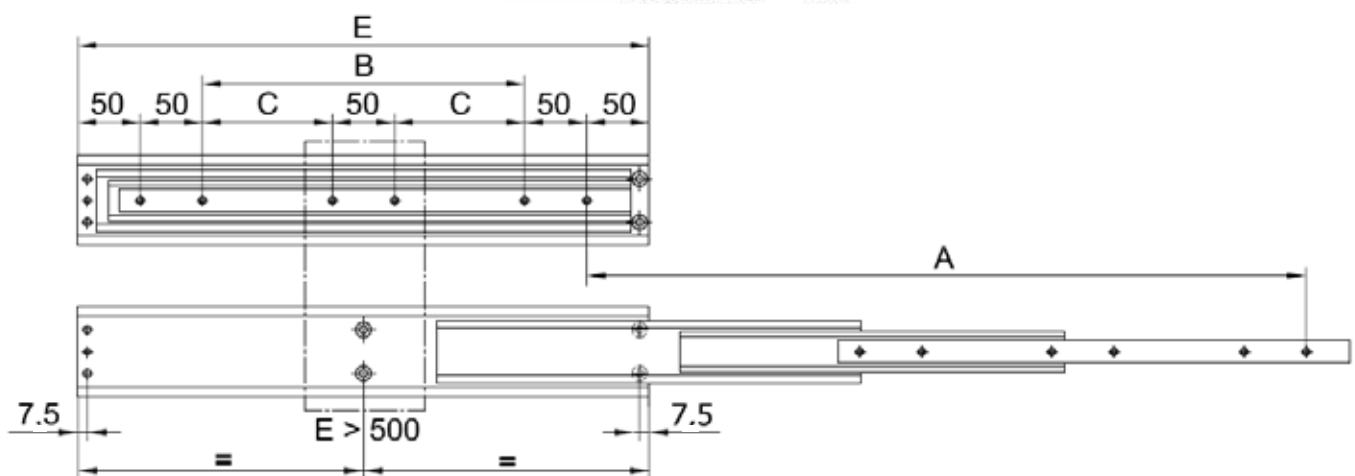
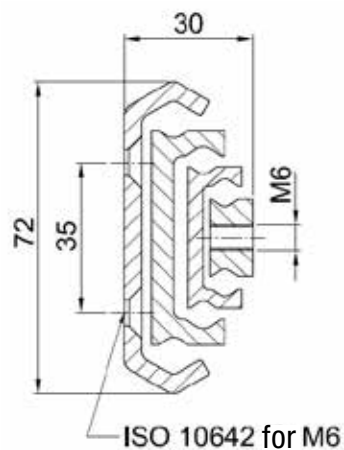

Load Table

| Order Number | Hole separation (mm) | | Installation length (mm) | Extension length (mm) | Net weight (kg) | Maximum load/pair (N) |
|----------------|----------------------|-----|--------------------------|-----------------------|-----------------|-----------------------|
| | B | C | | | | |
| NTU72-30T-300 | 100 | | 300 | 450 | 2.6 | 1380 |
| NTU72-30T-350 | 150 | | 350 | 525 | 3.0 | 1440 |
| NTU72-30T-400 | 200 | | 400 | 600 | 3.4 | 1500 |
| NTU72-30T-450 | 250 | | 450 | 675 | 3.9 | 1550 |
| NTU72-30T-500 | 300 | | 500 | 750 | 4.3 | 1500 |
| NTU72-30T-550 | | 150 | 550 | 825 | 4.7 | 1380 |
| NTU72-30T-600 | | 175 | 600 | 900 | 5.2 | 1320 |
| NTU72-30T-650 | | 200 | 650 | 975 | 5.6 | 1260 |
| NTU72-30T-700 | | 225 | 700 | 1050 | 6.0 | 1210 |
| NTU72-30T-750 | | 250 | 750 | 1125 | 6.4 | 1150 |
| NTU72-30T-800 | | 275 | 800 | 1200 | 6.9 | 1090 |
| NTU72-30T-850 | | 300 | 850 | 1275 | 7.3 | 1030 |
| NTU72-30T-900 | | 325 | 900 | 1350 | 7.7 | 980 |
| NTU72-30T-950 | | 350 | 950 | 1425 | 8.2 | 920 |
| NTU72-30T-1000 | | 375 | 1000 | 1500 | 8.6 | 860 |
| NTU72-30T-1100 | | 425 | 1100 | 1650 | 9.5 | 750 |
| NTU72-30T-1200 | | 475 | 1200 | 1800 | 10.3 | 630 |
| NTU72-30T-1300 | | 525 | 1300 | 1950 | 11.2 | 520 |
| NTU72-30T-1400 | | 575 | 1400 | 2100 | 12.0 | 400 |
| NTU72-30T-1500 | | 625 | 1500 | 2250 | 12.9 | 300 |

Ordercode and further options see last page. Your desired length is not listed in the table? No problem! Only the most common lengths are shown here. Please contact our application technology division.

NTU72-47.5DC

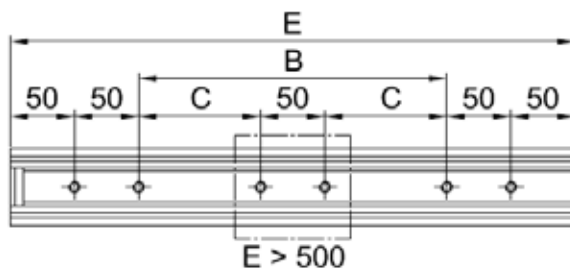
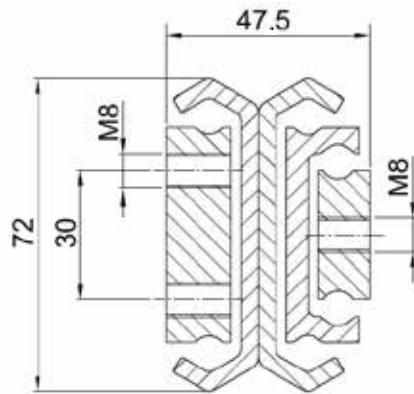

Load Table

| Order Number | Hole separation (mm) | | Installation length (mm) | Extension length (mm) | Net weight (kg) | Maximum load/pair (N) |
|-------------------|----------------------|-----|--------------------------|-----------------------|-----------------|-----------------------|
| | B | C | E | A | | |
| NTU72-47.5DC-300 | 100 | | 300 | 450 | 5.1 | 2500 |
| NTU72-47.5DC-350 | 150 | | 350 | 525 | 5.9 | 2600 |
| NTU72-47.5DC-400 | 200 | | 400 | 600 | 6.8 | 2650 |
| NTU72-47.5DC-450 | 250 | | 450 | 675 | 7.6 | 2700 |
| NTU72-47.5DC-500 | 300 | | 500 | 750 | 8.5 | 2700 |
| NTU72-47.5DC-550 | | 150 | 550 | 825 | 9.3 | 2650 |
| NTU72-47.5DC-600 | | 175 | 600 | 900 | 10.2 | 2600 |
| NTU72-47.5DC-650 | | 200 | 650 | 975 | 11.0 | 2550 |
| NTU72-47.5DC-700 | | 225 | 700 | 1050 | 11.9 | 2500 |
| NTU72-47.5DC-750 | | 250 | 750 | 1125 | 12.7 | 2450 |
| NTU72-47.5DC-800 | | 275 | 800 | 1200 | 13.6 | 2400 |
| NTU72-47.5DC-850 | | 300 | 850 | 1275 | 14.4 | 2350 |
| NTU72-47.5DC-900 | | 325 | 900 | 1350 | 15.3 | 2300 |
| NTU72-47.5DC-950 | | 350 | 950 | 1425 | 16.1 | 2250 |
| NTU72-47.5DC-1000 | | 375 | 1000 | 1500 | 17.0 | 2200 |
| NTU72-47.5DC-1100 | | 425 | 1100 | 1650 | 18.7 | 2100 |
| NTU72-47.5DC-1200 | | 475 | 1200 | 1800 | 20.4 | 1950 |
| NTU72-47.5DC-1300 | | 525 | 1300 | 1950 | 22.1 | 1800 |
| NTU72-47.5DC-1400 | | 575 | 1400 | 2100 | 23.8 | 1650 |
| NTU72-47.5DC-1500 | | 625 | 1500 | 2250 | 25.5 | 1500 |

Ordercode and further options see last page. Your desired length is not listed in the table? No problem! Only the most common lengths are shown here. Please contact our application technology division.

OVER EXTENSION

NTSU80-43

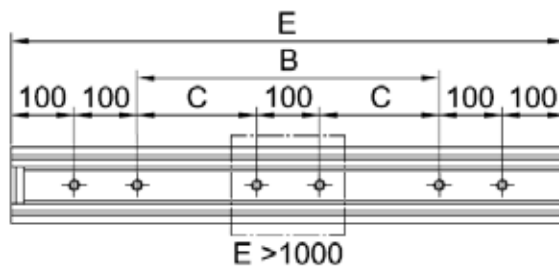
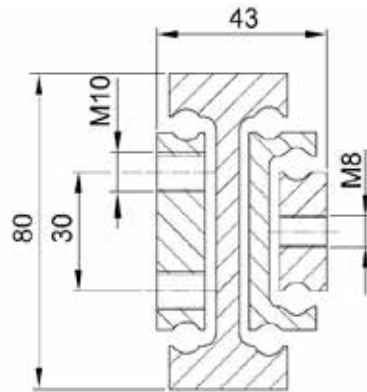

Load Table

| Order Number | Hole separation (mm) | | Installation length (mm) | Extension length (mm) | Net weight (kg) | Maximum load/pair (N) |
|----------------|----------------------|-----|--------------------------|-----------------------|-----------------|-----------------------|
| | B | C | E | A | | |
| NTSU80-43-500 | 100 | | 500 | 750 | 9.5 | 3200 |
| NTSU80-43-550 | 150 | | 550 | 825 | 10.4 | 3250 |
| NTSU80-43-600 | 200 | | 600 | 900 | 11.4 | 3300 |
| NTSU80-43-650 | 250 | | 650 | 975 | 12.3 | 3250 |
| NTSU80-43-700 | 300 | | 700 | 1050 | 13.3 | 3200 |
| NTSU80-43-750 | 350 | | 750 | 1125 | 14.2 | 3100 |
| NTSU80-43-800 | 400 | | 800 | 1200 | 15.1 | 3000 |
| NTSU80-43-850 | 450 | | 850 | 1275 | 15.9 | 2900 |
| NTSU80-43-900 | 500 | | 900 | 1350 | 17.0 | 2800 |
| NTSU80-43-950 | 550 | | 950 | 1425 | 17.9 | 2700 |
| NTSU80-43-1000 | 600 | | 1000 | 1500 | 18.8 | 2600 |
| NTSU80-43-1100 | | 300 | 1100 | 1650 | 20.7 | 2380 |
| NTSU80-43-1200 | | 350 | 1200 | 1800 | 22.5 | 2160 |
| NTSU80-43-1300 | | 400 | 1300 | 1950 | 24.4 | 1940 |
| NTSU80-43-1400 | | 450 | 1400 | 2100 | 26.2 | 1720 |
| NTSU80-43-1500 | | 500 | 1500 | 2250 | 28.1 | 1500 |

Ordercode and further options see last page. Your desired length is not listed in the table? No problem! Only the most common lengths are shown here. Please contact our application technology division.

NTSU80-79DS

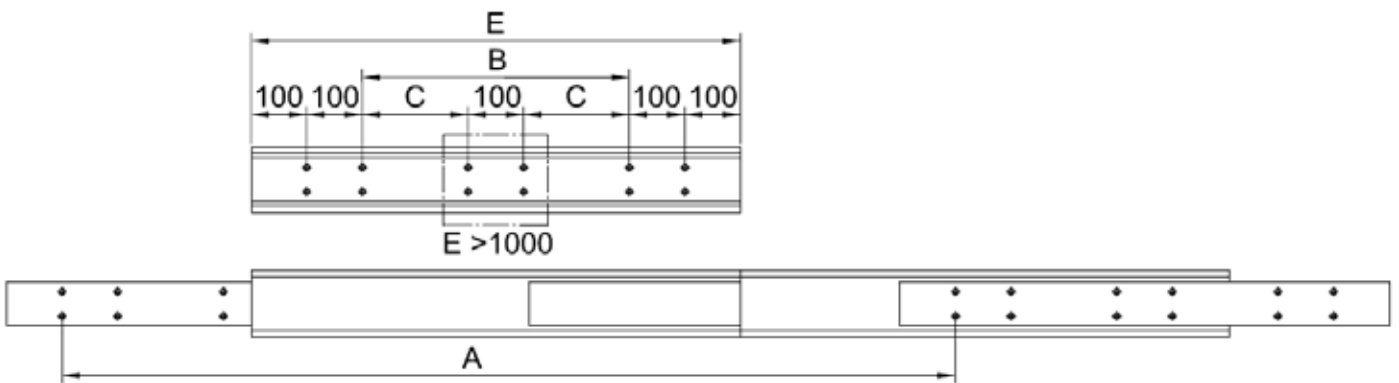
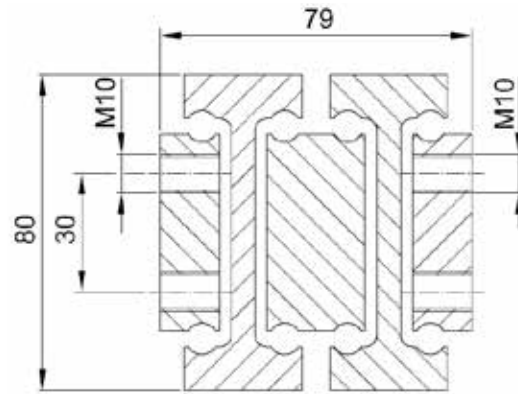

Load Table

| Order Number | Hole separation (mm) | | Installation length (mm) | Extension length (mm) | Net weight (kg) | Maximum load/pair (N) |
|------------------|----------------------|-----|--------------------------|-----------------------|-----------------|-----------------------|
| | B | C | E | A | | |
| NTSU80-79DS-500 | 100 | | 500 | 1000 | 17.6 | 10900 |
| NTSU80-79DS-550 | 150 | | 550 | 1100 | 19.3 | 11200 |
| NTSU80-79DS-600 | 200 | | 600 | 1200 | 21.1 | 11320 |
| NTSU80-79DS-650 | 250 | | 650 | 1300 | 22.8 | 11140 |
| NTSU80-79DS-700 | 300 | | 700 | 1400 | 24.8 | 10960 |
| NTSU80-79DS-750 | 350 | | 750 | 1500 | 26.3 | 10660 |
| NTSU80-79DS-800 | 400 | | 800 | 1600 | 28.0 | 10420 |
| NTSU80-79DS-850 | 450 | | 850 | 1700 | 29.8 | 10120 |
| NTSU80-79DS-900 | 500 | | 900 | 1800 | 31.5 | 9820 |
| NTSU80-79DS-950 | 550 | | 950 | 1900 | 33.3 | 9520 |
| NTSU80-79DS-1000 | 600 | | 1000 | 2000 | 35.0 | 9280 |
| NTSU80-79DS-1100 | | 300 | 1100 | 2200 | 38.5 | 8680 |
| NTSU80-79DS-1200 | | 350 | 1200 | 2400 | 42.0 | 8140 |
| NTSU80-79DS-1300 | | 400 | 1300 | 2600 | 45.4 | 7540 |
| NTSU80-79DS-1400 | | 450 | 1400 | 2800 | 48.9 | 6940 |
| NTSU80-79DS-1500 | | 500 | 1500 | 3000 | 52.4 | 6340 |

Ordercode and further options see last page. Your desired length is not listed in the table? No problem! Only the most common lengths are shown here. Please contact our application technology division.

OVER EXTENSION

NTSU100-51

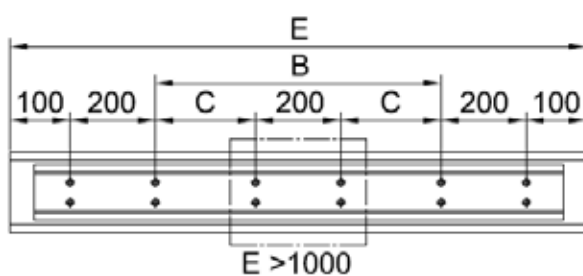
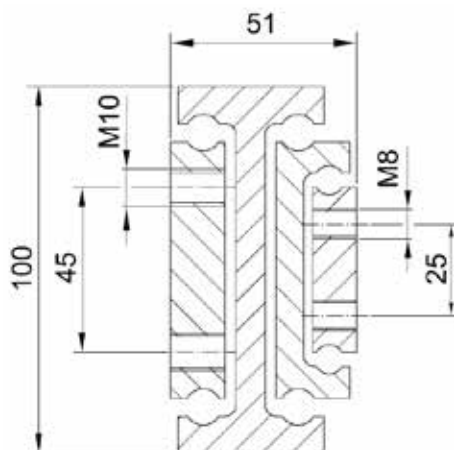

Load Table

| Order Number | Hole separation (mm) | | Installation length (mm) | Extension length (mm) | Net weight (kg) | Maximum load/pair (N) |
|-----------------|----------------------|-----|--------------------------|-----------------------|-----------------|-----------------------|
| | B | C | E | A | | |
| NTSU100-51-700 | 100 | | 700 | 1050 | 20.2 | 5600 |
| NTSU100-51-750 | 150 | | 750 | 1125 | 21.7 | 5600 |
| NTSU100-51-800 | 200 | | 800 | 1200 | 23.1 | 5400 |
| NTSU100-51-850 | 250 | | 850 | 1275 | 24.5 | 5200 |
| NTSU100-51-900 | 300 | | 900 | 1350 | 26.0 | 4800 |
| NTSU100-51-950 | 350 | | 950 | 1425 | 27.4 | 4600 |
| NTSU100-51-1000 | 400 | | 1000 | 1500 | 28.8 | 4400 |
| NTSU100-51-1100 | | 150 | 1100 | 1650 | 31.7 | 4100 |
| NTSU100-51-1200 | | 200 | 1200 | 1800 | 34.6 | 3800 |
| NTSU100-51-1300 | | 250 | 1300 | 1950 | 37.5 | 3500 |
| NTSU100-51-1400 | | 300 | 1400 | 2100 | 40.3 | 3200 |
| NTSU100-51-1500 | | 350 | 1500 | 2250 | 43.2 | 3000 |
| NTSU100-51-1600 | | 400 | 1600 | 2400 | 45.0 | 2700 |
| NTSU100-51-1700 | | 450 | 1700 | 2550 | 48.9 | 2400 |
| NTSU100-51-1800 | | 500 | 1800 | 2700 | 51.8 | 2100 |
| NTSU100-51-1900 | | 550 | 1900 | 2850 | 54.7 | 1800 |
| NTSU100-51-2000 | | 600 | 2000 | 3000 | 57.5 | 1500 |

Ordercode and further options see last page. Your desired length is not listed in the table? No problem! Only the most common lengths are shown here. Please contact our application technology division.

NTSU100-98DS

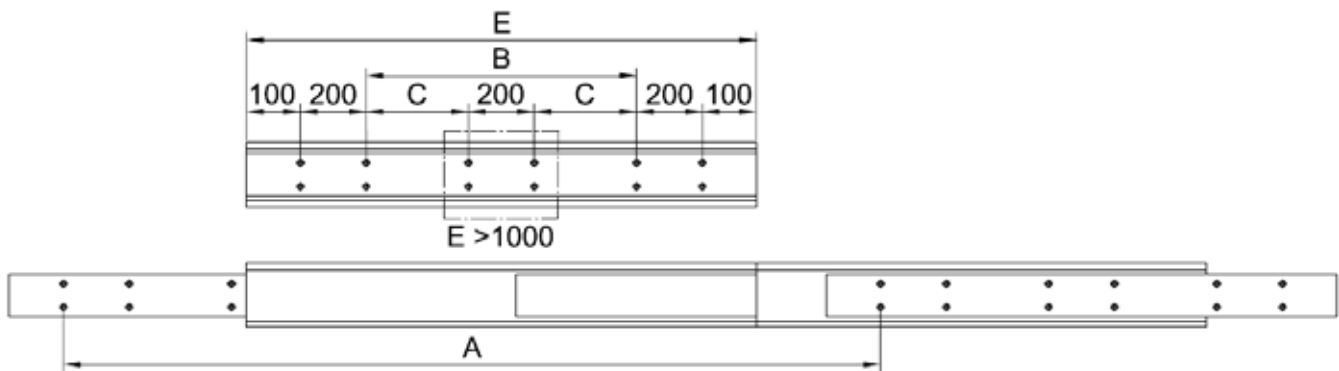
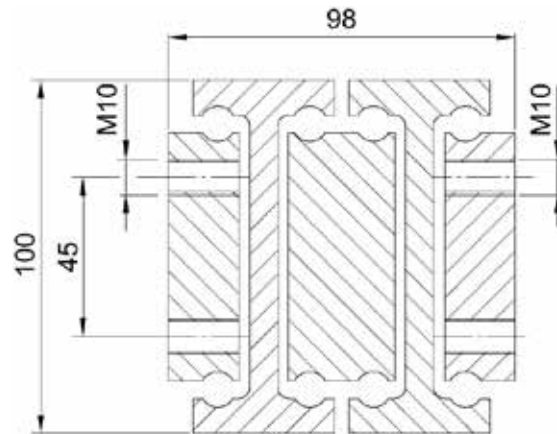

Load Table

| Order Number | Hole separation (mm) | | Installation length (mm) | Extension length (mm) | Net weight (kg) | Maximum load/pair (N) |
|-------------------|----------------------|-----|--------------------------|-----------------------|-----------------|-----------------------|
| | B | C | E | A | | |
| NTSU100-98DS-650 | 50 | | 650 | 1300 | 39.1 | 13925 |
| NTSU100-98DS-700 | 100 | | 700 | 1400 | 42.1 | 13700 |
| NTSU100-98DS-750 | 150 | | 750 | 1500 | 45.1 | 13325 |
| NTSU100-98DS-800 | 200 | | 800 | 1600 | 48.2 | 13025 |
| NTSU100-98DS-850 | 250 | | 850 | 1700 | 51.2 | 12650 |
| NTSU100-98DS-900 | 300 | | 900 | 1800 | 54.2 | 12275 |
| NTSU100-98DS-950 | 350 | | 950 | 1900 | 57.2 | 11900 |
| NTSU100-98DS-1000 | 400 | | 1000 | 2000 | 60.2 | 11600 |
| NTSU100-98DS-1100 | | 150 | 1100 | 2200 | 66.2 | 10850 |
| NTSU100-98DS-1200 | | 200 | 1200 | 2400 | 72.2 | 10175 |
| NTSU100-98DS-1300 | | 250 | 1300 | 2600 | 78.3 | 9425 |
| NTSU100-98DS-1400 | | 300 | 1400 | 2800 | 84.3 | 8675 |
| NTSU100-98DS-1500 | | 350 | 1500 | 3000 | 90.3 | 7925 |

Ordercode and further options see last page. Your desired length is not listed in the table? No problem! Only the most common lengths are shown here. Please contact our application technology division.

OVER EXTENSION

NTSU150-64

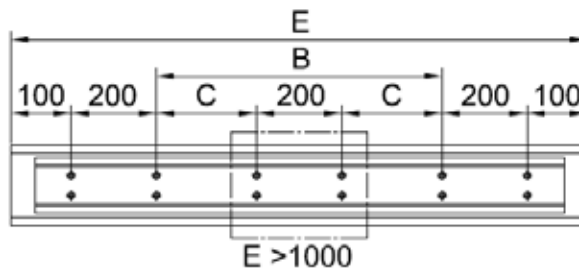
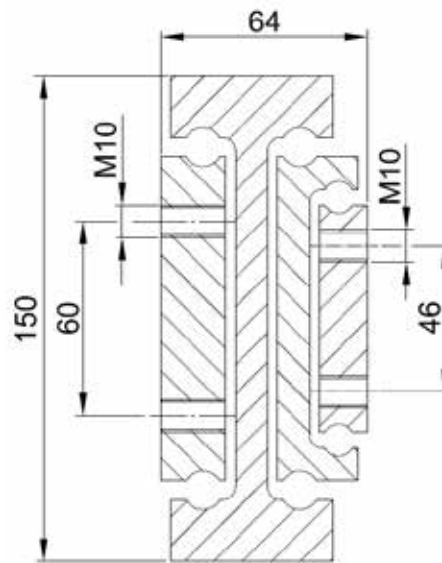

Load Table

| Order Number | Hole separation (mm) | | Installation length (mm) | Extension length (mm) | Net weight (kg) | Maximum load/pair (N) |
|-----------------|----------------------|-----|--------------------------|-----------------------|-----------------|-----------------------|
| | B | C | E | A | | |
| NTSU150-64-700 | 100 | | 700 | 1050 | 38.1 | 7100 |
| NTSU150-64-750 | 150 | | 750 | 1125 | 40.8 | 7200 |
| NTSU150-64-800 | 200 | | 800 | 1200 | 43.5 | 7600 |
| NTSU150-64-850 | 250 | | 850 | 1275 | 46.2 | 7500 |
| NTSU150-64-900 | 300 | | 900 | 1350 | 48.9 | 7350 |
| NTSU150-64-950 | 350 | | 950 | 1425 | 51.6 | 7200 |
| NTSU150-64-1000 | 400 | | 1000 | 1500 | 54.3 | 7000 |
| NTSU150-64-1100 | | 150 | 1100 | 1650 | 59.7 | 6600 |
| NTSU150-64-1200 | | 200 | 1200 | 1800 | 65.2 | 6200 |
| NTSU150-64-1300 | | 250 | 1300 | 1950 | 70.5 | 5800 |
| NTSU150-64-1400 | | 300 | 1400 | 2100 | 75.9 | 5300 |
| NTSU150-64-1500 | | 350 | 1500 | 2250 | 81.3 | 4800 |
| NTSU150-64-1600 | | 400 | 1600 | 2400 | 86.8 | 4300 |
| NTSU150-64-1700 | | 450 | 1700 | 2550 | 92.2 | 3800 |
| NTSU150-64-1800 | | 500 | 1800 | 2700 | 97.6 | 3300 |
| NTSU150-64-1900 | | 550 | 1900 | 2850 | 103.0 | 2800 |
| NTSU150-64-2000 | | 600 | 2000 | 3000 | 108.5 | 2400 |

Ordercode and further options see last page. Your desired length is not listed in the table? No problem! Only the most common lengths are shown here. Please contact our application technology division.